

003391

Operating Instructions

Panasonic

HI-FI COMPONENTS

Panasonic



CD-4 SYSTEM AUTOMATIC TURNTABLE

MODEL **SL-800**

Before operating this unit, please read these instructions completely.

Dear Stereo Fan

Thank you very much for selecting the Panasonic model
SL-800 CD-4 SYSTEM AUTOMATIC TURNTABLE.

PREPARATIONS

- (1) Loosen the 2 transit screws by turning them clockwise.
This lifts the record changer into the necessary floating
mount position.
- (2) Unscrew the turntable and motor tie-down screws (which
keep turntable and motor stationary during shipping) by
turning them counterclockwise.

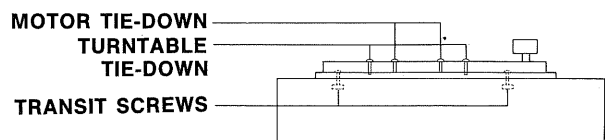
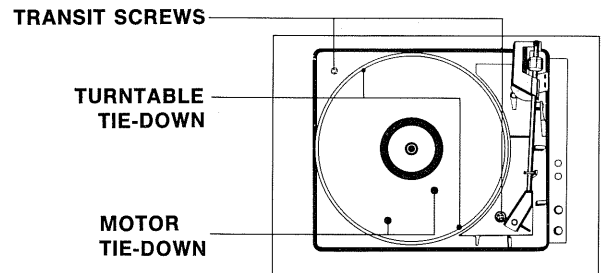
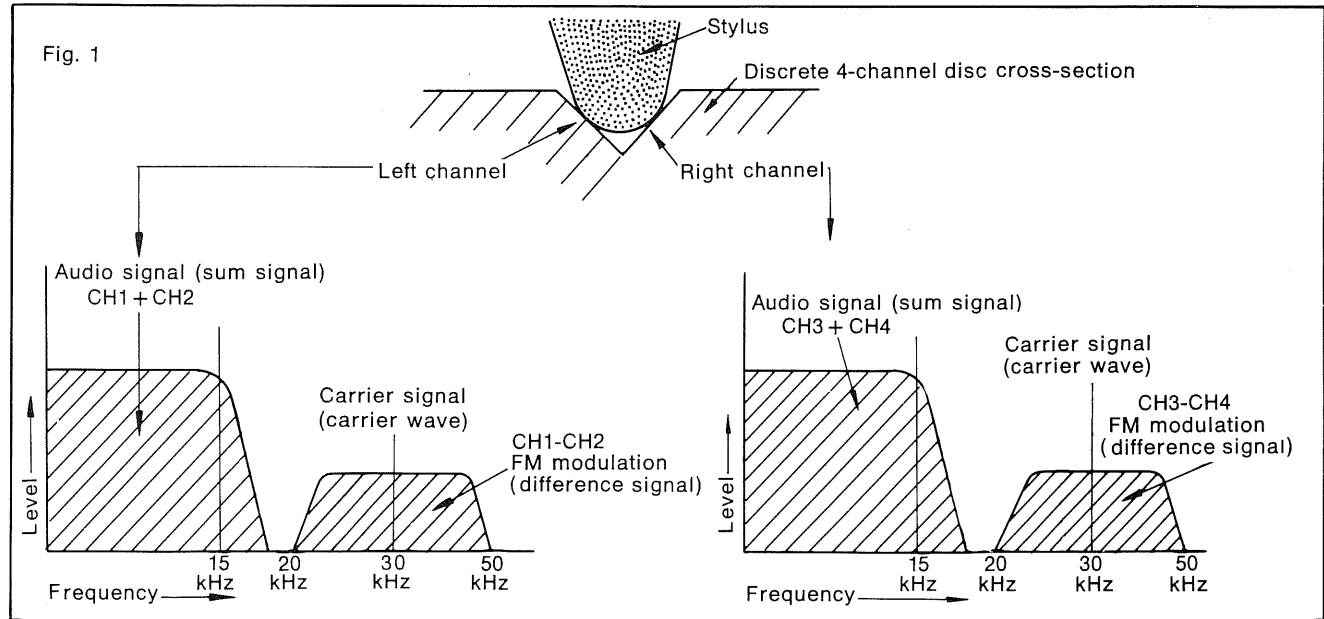

Fig. 1

A BRIEF EXPLANATION OF THE CD-4 SYSTEM

RECORDING



The following is a brief explanation of how four sounds, each independent of the other, are obtained from one groove of a disc.

By studying the disc cross-section shown in figure 1, it will be recognized as the 45-45 system, the same as conventional stereo. On the left channel of the sound groove, however, are inscribed both the audio signal (the sum signal)—made up of channels one and two—as well as the carrier signal (the carrier)—which has been FM- and

PM-modulated by the audio signal (the difference signal) made up of the difference between CH1 and CH2.

(FM=frequency modulation; PM=phase modulation)

Of these two signals, the carrier signal varies from 20 kHz to 50 kHz as a result of being FM-modulated.

In the same way, the right channel is inscribed with the CH3+CH4 audio signal and with the carrier signal—which has been modulated by the signal which is the difference between CH3-CH4.

PLAYBACK

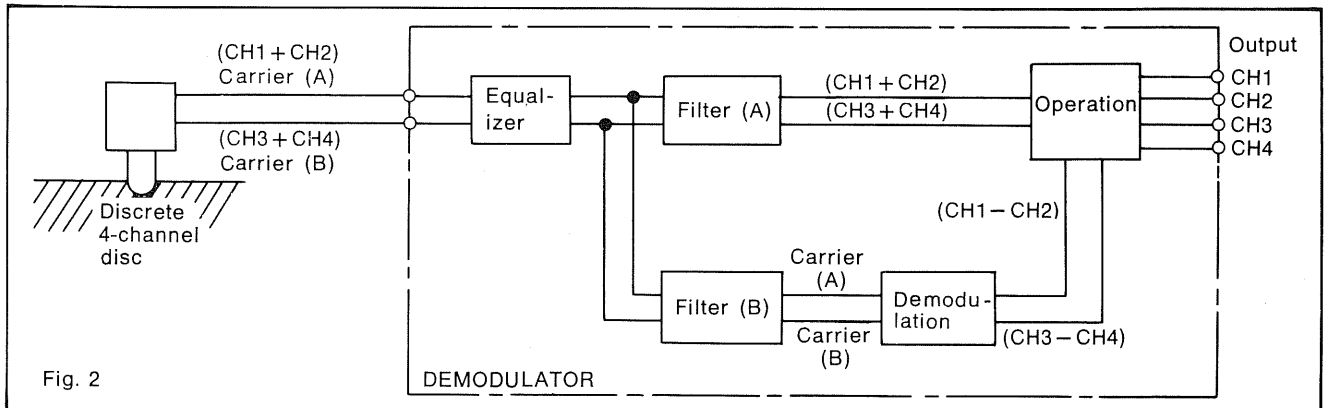

The block diagram will serve to explain how four independent sounds are picked up from the discrete 4-channel disc. First, both the sum signal of CH1 + CH2 and the carrier signal (which has been modulated by the difference signal of CH1-CH2) are picked up from the left channel of the disc by the CD-4 cartridge and are sent to this unit, where they enter, without change, filter A and filter B after passing through the equalizer (RIAA curve). These filters separate the signals into (1) the sum signal of CH1+CH2 and (2) the modulated carrier signal. The sum signal enters the operation circuitry without change, while the modulated carrier signal passes through the demodulation circuitry

and enters the operation circuitry, becoming the CH1-CH2 difference signal (which was the modulation wave). Then addition and subtraction are accomplished by the operation circuitry.

Specifically:

$$\text{Addition: } (CH1 + CH2) + (CH1 - CH2) = 2(CH1)$$

$$\text{Subtraction: } (CH1 + CH2) - (CH1 - CH2) = 2(CH2)$$

By this process, CH1 and CH2 are sent to the output.

In the same way, the signal picked up from the right channel of the disc is sent out as CH3 and CH4. This explanation has, we hope, served to explain how four signals are picked up from one groove of a disc as completely independent sound.

CONTROL PANEL



① POWER SWITCH LAMP

This lamp illuminates to indicate that the unit is receiving power. To turn on the power, move the start lever to the START position.

② 4 CH RADAR

When a discrete 4-channel disc is played, this lamp illuminates. When a conventional 2-channel disc is played, this lamp will not illuminate.

③ FUNCTION SELECTOR

PHONO.....For reproduction of discrete 4-channel or 2-channel stereo discs.

4 CH AUX...When this switch is pushed, the unit is in the [4 CH AUX] mode.

Used in this mode only

For reproduction of other 4-channel sources (output of a 4-channel tape deck, etc.) connected to the "4 CH AUX INPUT" terminals of this unit. Therefore, if the output of a discrete 4-channel tape deck is connected to the "4 CH AUX INPUT" terminals, reproduction of both discrete 4-channel discs and 4-channel tape can be easily accomplished.

④ MODE SELECTOR

4 CH AUTO...For reproduction of discrete 4-channel program sources. If conventional 2-channel program sources are played with this switch set to this position, the unit automatically functions as an equalizer amplifier. Signal output is received in the same way as in the "STEREO" position.

STEREOWhen this switch is pushed, the unit is in the [STEREO] mode.

For reproduction of conventional 2-channel program sources. At this time, this unit functions as an equalizer amplifier. The left signals can be heard from the front and rear left, and the right signals from the front and rear right.

REAR PANEL

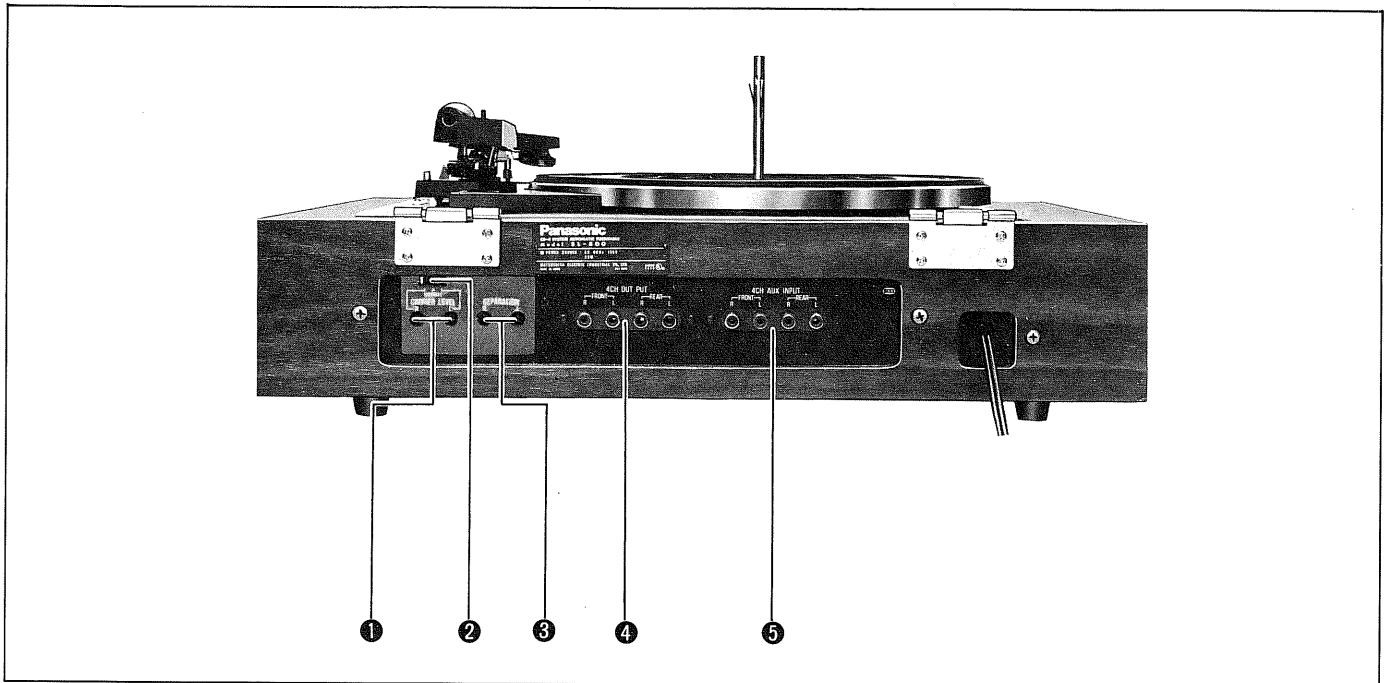

① CARRIER LEVEL (L) (R)

To adjust the left and right cartridge level. Used to compensate for the different output levels of the 30 kHz carrier signal from various types of cartridges.

See "page 9" for further adjustment procedures.

② CARRIER LEVEL ADJUSTMENT SWITCH

Use this switch to adjust the 30 kHz carrier level of this unit (using carrier level volume control ①).

L: Set to this position to adjust the left input.

R: Set to this position to adjust the right input.

NORMAL: Set to this position after the left and right adjustments are completed. (Refer to [carrier level adjustment] on page 9 for further operation information.)

③ SEPARATION (L) (R)

To adjust the separation of the left front to left rear and right front/right rear. The characteristics of the 4-channel cartridge being used will affect the separation of 4-channel signals. Be sure to adjust the separation (by using the included disc) every time another 4-channel cartridge is used.

④ 4 CH OUTPUT TERMINALS

The output terminals for 4-channel performance. Connect these terminals to the 4-channel input terminals of the amplifier, receiver, etc.

⑤ 4 CH AUX INPUT TERMINALS

For connection of another 4-channel program source, such as a 4-channel discrete tape deck or matrix 4-channel, etc

CONNECTIONS FOR CD-4 SYSTEM

CONNECTIONS

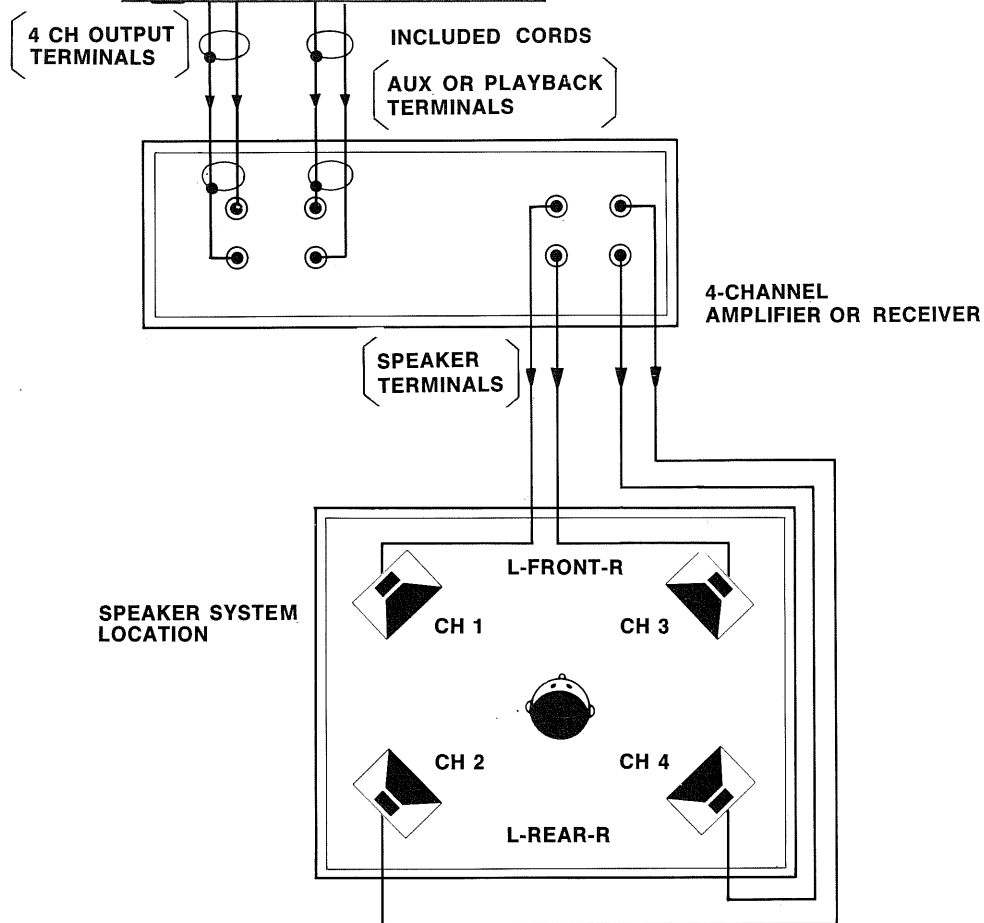
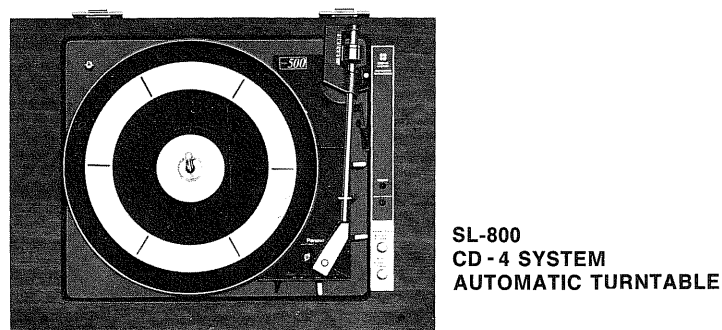

FIGURE INDICATIONS ARE AS FOLLOWS

- LEFT FRONT SIGNALL, FRONT (CH 1)
- RIGHT FRONT SIGNALR, FRONT (CH 3)
- LEFT REAR SIGNALL, REAR (CH 2)
- RIGHT REAR SIGNALR, REAR (CH 4)

NOTES:

- To operate this unit with receivers or amplifiers, connect to the AUX or PLAYBACK terminals of the amplifiers.
- After connections are completed, please carefully read "Preparations before use" on page 9 before actually beginning operation.

IN COMBINATION WITH A 4-CHANNEL RECEIVER

CONNECTIONS

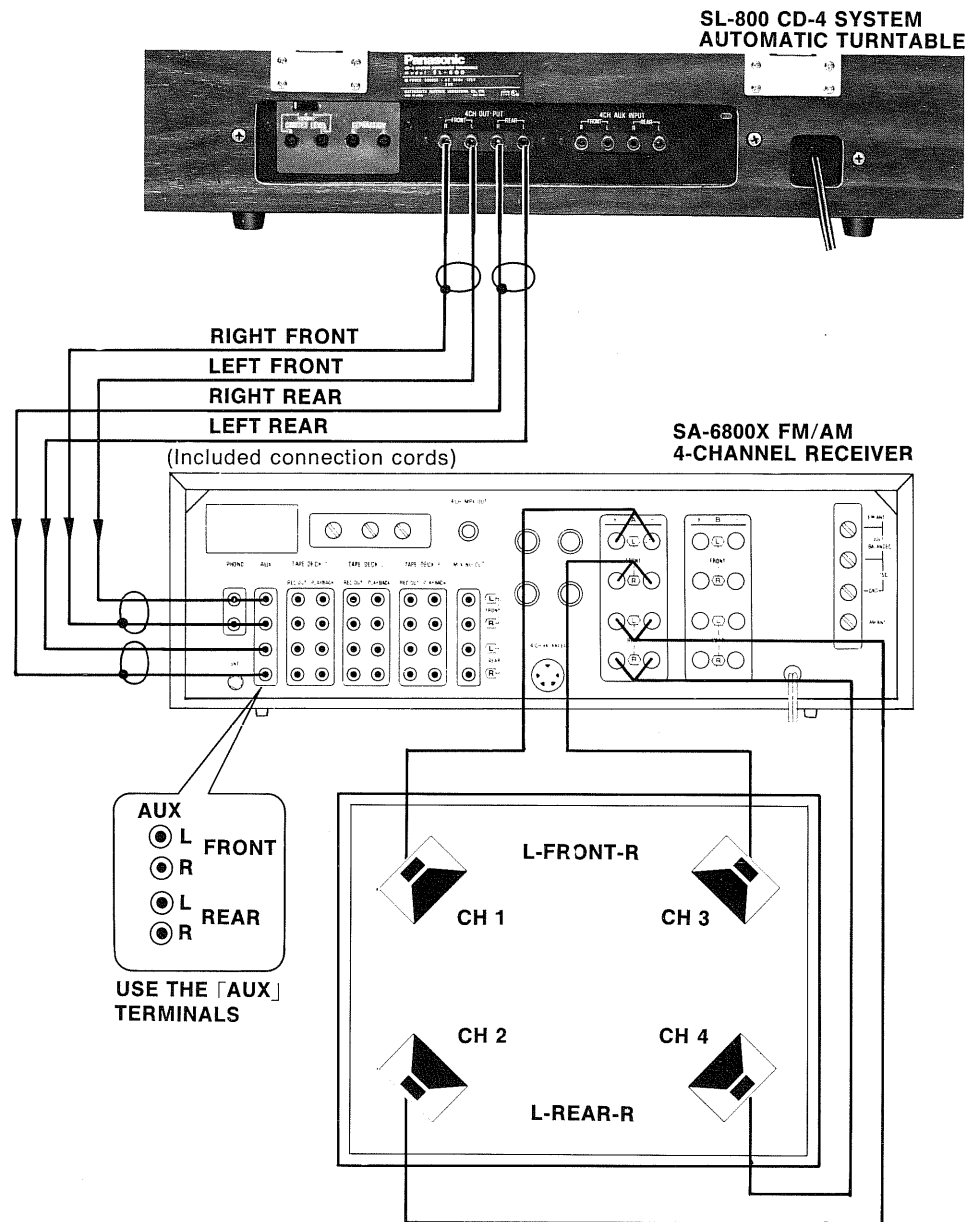

OPERATION:

For 4-channel receiver operation

(Such as, for example, the model SA-6800X FM/AM 4-channel receiver)

- ❶ Set the power switch to the ON position.
- ❷ Push the AUX input select pushbutton.
- ❸ Set the mode selector to the Q'SONIC AFD OFF position.
- ❹ Set the speaker selector to the desired position.

Operation of automatic turntable SL-800

- ❶ Set the function selector to the PHONO position, and the mode selector to the 4 CH AUTO position.
 - ❷ Set the start lever to the START position; this will turn the power on and start turntable rotation.
- **Disc playing**
- ❶ Set the channel level control of the receiver to the "5" position, and increase the volume level with the volume control.
 - ❷ Adjust the front, rear, right and left balance of the volume level with the channel level control.

IN COMBINATION WITH 2-CHANNEL RECEIVER

CONNECTIONS

(Two units are necessary)

Connect to the AUX or PLAYBACK terminals of the receivers.

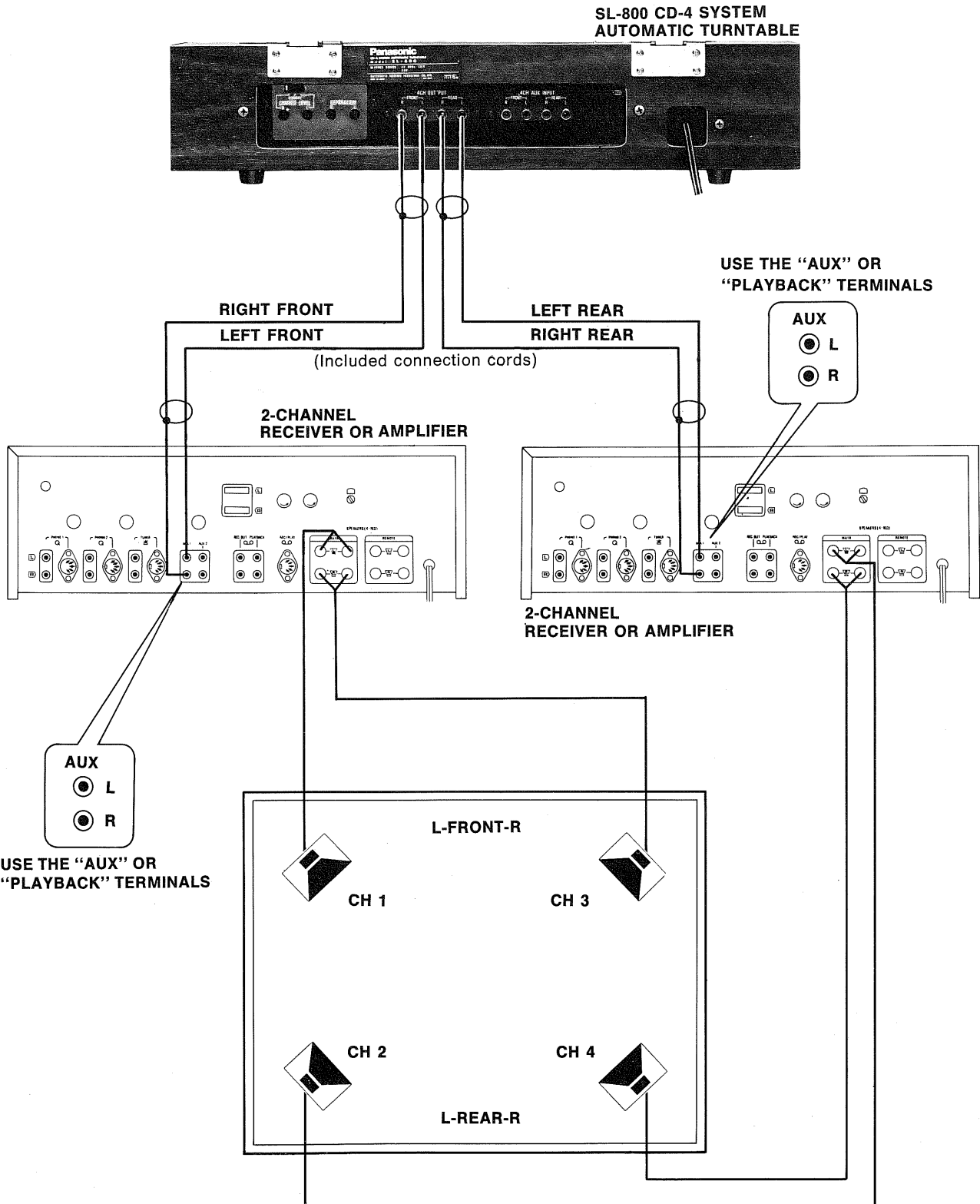

CONNECTION OF OTHER 4-CHANNEL PROGRAM SOURCE

CONNECTIONS

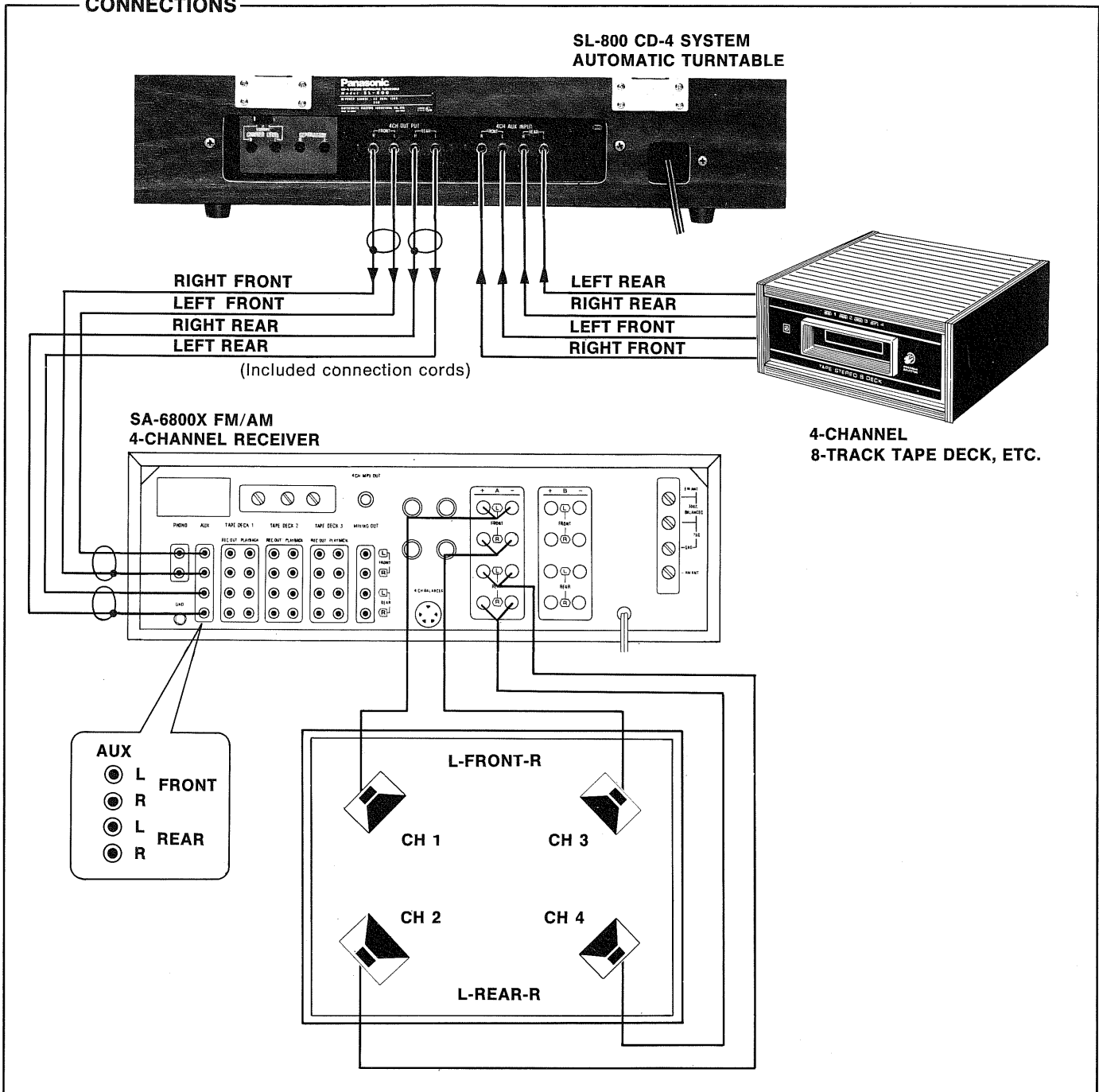

OPERATION:

(Reproduction in combination with 4-channel disc)

Set the function selector according to the sound source:
CD-4 disc and other sources.

Operation

- ① Set the mode selector to the 4 CH AUTO position.
- ② Set the function selector to
 - the PHONO position to reproduce CD-4 disc
 - the 4 CH AUX position to reproduce other sources.

Note:

- To connect the output of 2-channel sources, connect the left 2-channel source to the FRONT L position of 4 CH AUX INPUT, and connect the right output to the FRONT R position.
- The input connected to the 4 CH AUX INPUT terminal will be emitted directly from the 4 CH OUTPUT terminal.

PREPARATIONS BEFORE USE

ADJUSTMENT OF SEPARATION AND CARRIER LEVEL

Because the two adjustments for separation and 30 kHz carrier level adjustment signal have already been made in this unit, do not ordinarily move the separation and carrier level volume controls.

Make adjustments according to the following instructions, however, when the 4-channel cartridge is replaced or when the adjustment is disturbed by accident.

Preliminary operations

- (1) Set the function selector of this unit to the PHONO position and mode selector to the 4 CH AUTO position.
- (2) Set the start lever to the START positioning; this will turn the power on and start turntable rotation.
 - Confirm the presence of sound from the speaker of each channel while playing side A of the included discrete 4-channel disc.

Separation adjustments

Side A of the included disc has a tone suitable for adjustment of the separation. The signal lasts 30 seconds for the left side and another 30 seconds for the right side.

Adjustment procedures

- (1) Turn the left and right carrier level adjustment volume controls (located at the rear of the unit) clockwise to the maximum position. (Fig. 1)
- (2) Play the disc and set the loudness control volume of the front left (CH 1) and front right (CH 3) to minimum position.
- (3) During the first 30 seconds (as the separation adjustment signals for the left side are reproduced), turn the left separation adjustment volume control (L) to set the volume level of the rear left (CH 2) to minimum (using the screwdriver.) (Fig. 2)
- (4) In the same way, turn the right separation adjustment volume control (R) to set the volume level of the rear right (CH 4) to minimum during the 30 seconds when the separation adjustment signal for the right side is reproduced. (Fig. 2)
- (5) The separation adjustment is now completed. Return the loudness volume controls for front left (CH 1) and right (CH 3) (which were set to minimum) to their original positions.

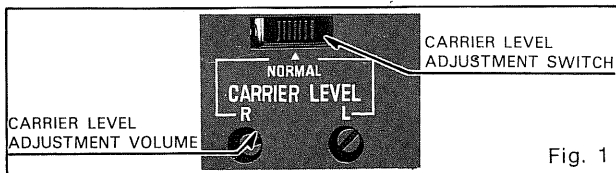

- (6) Then adjust the volume balance so that the volume levels of each channel are the same, referring to the sound heard from each channel. This concludes the separation adjustment.

Carrier level adjustment

This adjustment aims at bringing the unit to the most suitable condition for the output level of each cartridge. By way of this adjustment, play a 12" (30-cm) CD-4 disc in its outermost grooves and balance the right channels with the left.

Adjustment procedures

- (1) Before adjustment, turn the carrier level volume controls (L) and (R) counterclockwise to the minimum position. (Fig. 1)
- (2) Left side adjustment:
 - Set the carrier level adjustment switch to the (L) position. (Fig. 1)
 - Play a CD-4 disc in its outermost grooves and turn the 30 kHz carrier level adjustment volume control "L" clockwise. The "4 CH RADAR" indicator on the front of the unit will light up. At the moment it does light, stop turning. (Fig. 1)
- (3) Right side adjustment:
 - Set the carrier level adjustment switch to the (R) position. (Fig. 1)
 - Play a CD-4 disc in its outermost grooves and turn the 30 kHz carrier level adjustment volume control "R" clockwise until the "4 CH RADAR" is lighted up. Be sure to stop turning the control when the "4 CH RADAR" is lighted up. (Fig. 1)
- (4) When left and right side adjustments are completed, set the carrier level adjustment switch to the (NORMAL) position.

(Note)
Stop turning immediately when the "4 CH RADAR" lights up for optimum adjustment. Do not turn it further. If turned too far, re-adjustment will be necessary.

This concludes all adjustments of this unit.

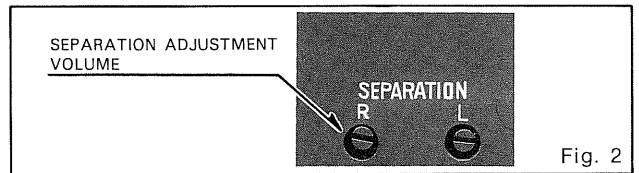

MOST EFFECTIVE SPEAKER LOCATION FOR 4-CHANNEL SOUND REPRODUCTION

- This figure at the right shows the placement of the speakers. Because the listener is surrounded by four sounds, this arrangement is ideal for popular music, on-the-spot recordings and mood music. This is also the best placement to obtain a unique 4-channel effect of sounds moving continually around the listener.

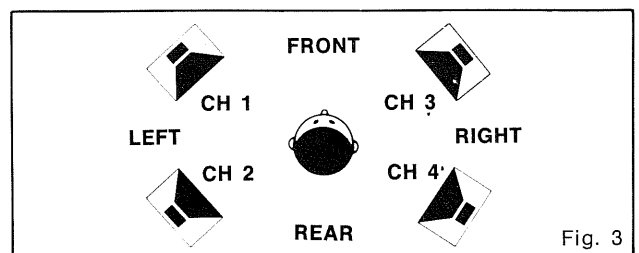

CARTRIDGE REPLACEMENT

TO REPLACE THE CARTRIDGE

Replace the cartridge according to the following instructions.

- (1) Loosen the cartridge holding screw to remove the old cartridge from the pickup arm. (See fig. 1).
- (2) Install the new cartridge. (Fig. 7, 8)
- (3) Loosen the balancer holding screw and set the index line on the balancer to the [0] position on the stylus pressure scale. After this is done, move the pickup away from the pickup rest and adjust the pickup to be horizon-

tal by turning the balance adjustment screw. (See Figs. 2, 3, 4 and 5).

- (4) When the pickup is horizontal, set the index line on the balancer to the "3" position on the stylus pressure scale and re-tighten the balancer screw. The adjustments are then completed. (See fig. 6.)
- (5) Set the anti-skating control knob to the stylus pressure designated for the new cartridge. (Refer to the [ANTI-SKATING CONTROL] on page 12.)

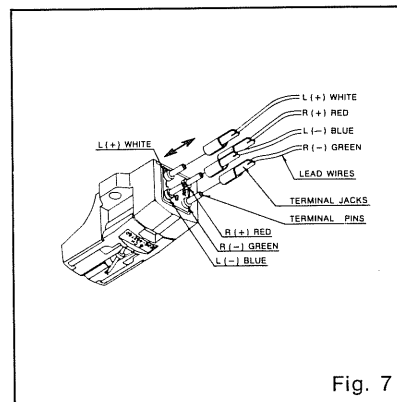
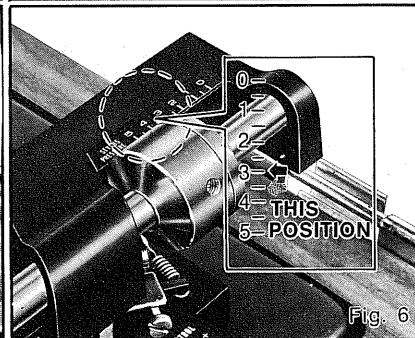
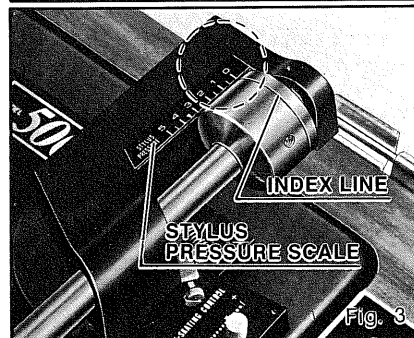
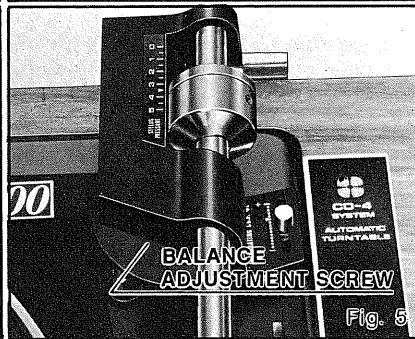
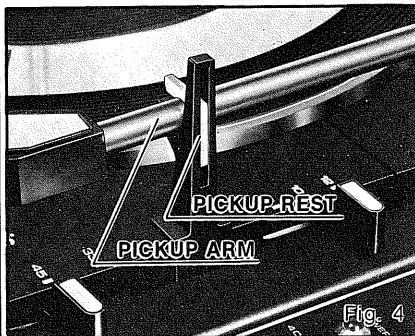
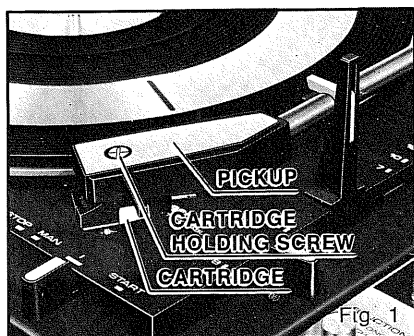

Fig. 7

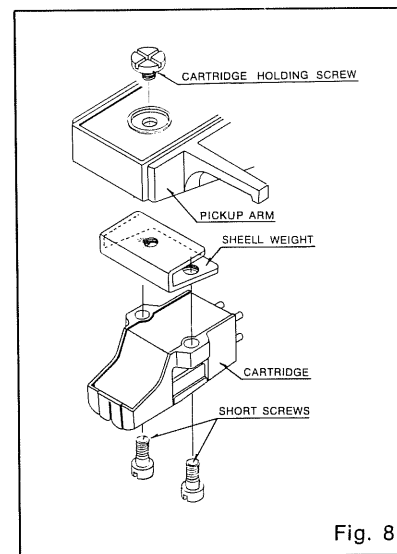

Fig. 8

MAINTENANCE

ADJUSTMENT

This unit has been subjected to the most rigorous checks and tests before leaving the factory, where all necessary adjustments have been made to ensure satisfactory playing of discs.

The following information is provided should it become necessary to make any minor adjustments.

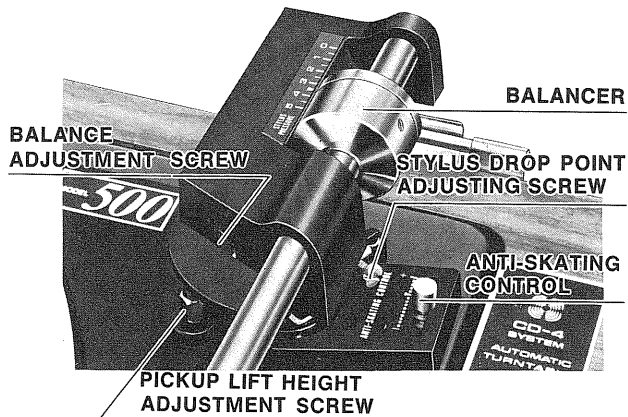

ANTI-SKATING CONTROL

Having set the required stylus pressure at 3.0g and the anti-skating control knob to the ► position, the anti-skating force is adjusted to correspond to the stylus pressure applied. Moving the knob toward + increases the anti-skating force and toward - reduces the force.

Note: The anti-skating control adjustments described are those required for ideal conditions.

Slight variations from the optimum may be necessary depending on the condition of the stylus.

If, after adjusting the force, the pickup tends to skate outward, lower the adjustment; if it skates inward, increase the adjustment.

STYLUS DROP POINT

Turning the stylus drop-point adjustment screw clockwise moves the pickup inwards; counterclockwise moves it outwards.

PICKUP LIFT HEIGHT

If the pickup does not lift high enough to clear the top disc on the stack when returning to its rest, turn the pickup lift height adjustment screw counterclockwise to raise the pickup.

The stylus should be 0.625 inch above the face of a single disc on the turntable as the pickup returns to its rest. Turning clockwise, the pickup is lowered.

TO REMOVE THE TURNTABLE

Disconnect the power supply and withdraw the disc spindle. Then remove the turntable rubber mat and pry off clip,

noting its position (small hole facing rear left) for assembly, and lift the turntable with equal pressure on opposite sides.

LUBRICATION

When the need for lubrication is apparent, remove the turntable and apply a drop or two of light machine oil (sewing machine oil is suitable) to the bearings of the rubber intermediate wheel, turntable spindle and motor. Take great care to keep all driving surfaces clean and dry to prevent them from slipping. The control arm must lower freely. If it does not, clean and lightly oil its spindle.

DUST COVER REMOVAL

The dust cover of this unit is removable, if desired, depending upon the location in which this unit is used. To remove the cover, close it and lift it up.

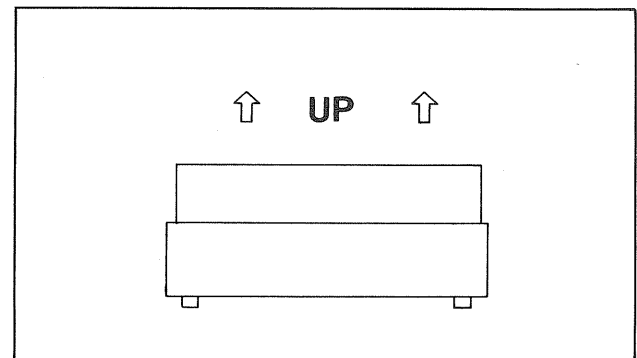

REPLACEMENT OF STYLUS

A diamond stylus is used in this pickup. If the diamond stylus is used for about 400 hours, the point of the diamond stylus will become worn, resulting in poor tone quality, and easily spoiling discs.

Replace with stylus:

EPS-451QD (diamond) for 4-channel discs.

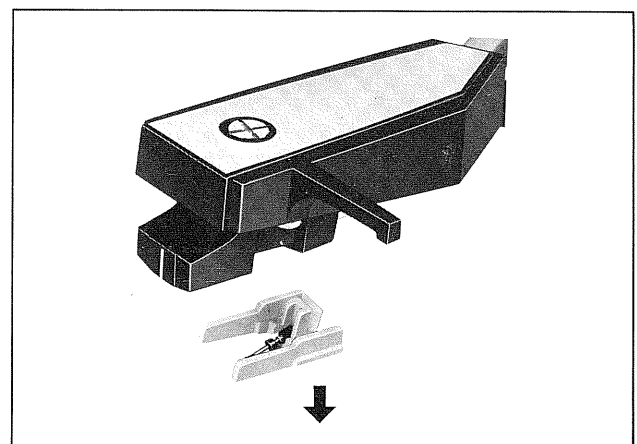

TROUBLESHOOTING GUIDE

Any "trouble" which might be noted in a system including the CD-4 system can usually be traced to the disc, the cartridge, the turntable, the demodulator, or the connections between these, or to the manner in which one or all of these are operated. Even though the symptom seems to indicate the fault to be in one component, careful examination often shows it to be elsewhere, or to be an outside cause, or indeed due to incorrect operation. In addition,

sound reproduction becomes ever more faithful to the original as improvements are made in the manufacture of high fidelity components, making the listener ever more conscious of noise which, until recently, was "hidden" within the music itself. The following table can be successfully used to locate the cause, and provide the corresponding remedy, of many of the problems which may be encountered.

Symptom	Main cause	Remedy
<ul style="list-style-type: none"> Abnormal noise <p>Noise is heard at the "4CH AUTO" position but not at the "STEREO" position during performance of a discrete 4-channel disc.</p>	<ul style="list-style-type: none"> The stylus is worn out. 	<ul style="list-style-type: none"> The stylus can be used for 300 to 400 hours. If used longer, noise is apt to increase and, moreover, the disc may be damaged. It should be replaced with a new one.
	<ul style="list-style-type: none"> There is dust on the disc or on the tip of the stylus. 	<ul style="list-style-type: none"> Any dust on the surface of the disc is apt to interfere with satisfactory reproduction. Be sure, therefore, to clean away dust completely, using a cleaner or other effective method. To remove dust from the tip of the stylus, use the included stylus cleaner. (See Fig. 1 on page 14)
	<ul style="list-style-type: none"> The cartridge is mounted incorrectly. 	<ul style="list-style-type: none"> Be sure that the cartridge is mounted correctly.
<ul style="list-style-type: none"> Abnormal noise, continually or intermittently. Left/right sound separation is unsatisfactory. 	<ul style="list-style-type: none"> This unit is located near a television set. 	<ul style="list-style-type: none"> Maintain a distance of more than 2 feet between this unit and the television set.
	<ul style="list-style-type: none"> Cartridge mounted incorrectly. 	<ul style="list-style-type: none"> Be sure the cartridge is mounted correctly.
	<ul style="list-style-type: none"> Stylus pressure is incorrect. 	<ul style="list-style-type: none"> Be sure that the stylus pressure is set to the position specified for the cartridge.
<ul style="list-style-type: none"> Distortion in the sound, or unusual vibration. 	<ul style="list-style-type: none"> The stylus pressure is incorrect. 	<ul style="list-style-type: none"> Be sure that the stylus pressure is set to the specified pressure for the cartridge.
	<ul style="list-style-type: none"> There is dust on the disc or on the tip of the stylus. 	<ul style="list-style-type: none"> Dust on the disc should be removed with a cleaner. Dust on the tip of the stylus should be removed with the included stylus cleaner.
	<ul style="list-style-type: none"> The stylus tip is worn. 	<ul style="list-style-type: none"> The stylus can be used for 300 to 400 hours. If used longer, noise is apt to increase and, moreover, the disc may be damaged. It should be replaced with a new one.
<ul style="list-style-type: none"> Front/rear separation is unsatisfactory. 	<ul style="list-style-type: none"> The stylus pressure is incorrect. 	<ul style="list-style-type: none"> Be sure that the stylus pressure is set to the specified pressure for the cartridge.
	<ul style="list-style-type: none"> The cartridge phase is reversed. 	<ul style="list-style-type: none"> Connect properly, as shown in Fig. 7 on page 11.
	<ul style="list-style-type: none"> The disc or the stylus is dirty. 	<ul style="list-style-type: none"> Use a cleaner to remove dust from the disc, use the included stylus cleaner to remove dust on the tip of the stylus.

The term CD-4 disc used in these operating instructions refers to any discrete 4-channel disc, including those labeled "Quadradisc (RCA)", "CD-4", etc.

HOW TO USE THE STYLUS CLEANER

• If the stylus is used with dust or dirt on its tip, it will not contact the disc groove completely, nor trace perfectly, resulting in sound deterioration as well as damage to both the disc and the stylus tip. Be sure, therefore, to clean away dust and dirt carefully with the included stylus cleaner, moving it from the base of the stylus-lever toward the stylus tip. (Refer to figure 1.)

Be especially careful to clean away all dust and dirt from the stylus tip before playing discrete 4-channel discs because such dust may result in abnormal noise.

Stylus Cleaner for superior sound

Take off cap, moisten brush by moving bottle from side to side, and clean up stylus tip by brushing it several times.

CAUTION

- (1) Tighten cap after use.
- (2) Non-toxic, but don't swallow contents.
- (3) Combustible; keep away from heat or flame.

- (4) Avoid prolonged exposure to sunlight.
 - (5) Keep out of reach of children.
- Clean discs with a good quality disc cleaner.

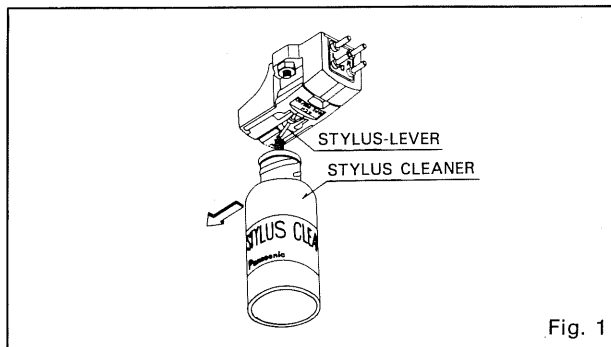

Fig. 1

SPECIFICATIONS

TURNTABLE SECTION

- | | |
|---------------------------------|---|
| Changer: | • Umbrella Type
Fully Automatic (Multi play, Single play, Manual play) |
| Turntable: | • 11 inch Full Size (Die-Cast) |
| Drive: | • Rim Drive Type |
| Motor: | • 4-pole Induction Type |
| Turntable Speed: | • 3-Speed 33 1/3, 45, 78 r.p.m. |
| Total Wow & Flutter: | • 0.15% (WRMS) |
| SN ratio: | • 35 dB |
| Tone Arm: | • Dynamic Balanced Tubular Type with Anti-Skating Control,
Oil Damped Cueing |
| Cartridge: | • Semiconductor (for discrete 4-channel disc reproduction) |
| Stylus: | • Diamond |
| Stylus Pressure: | • 3 g |

DEMODULATOR SECTION

- | | |
|--------------------------------|--|
| Frequency Response: | • 20~16,000 Hz |
| Rated Output Level: | • 300 mV |
| Output Impedance: | • 2.2 k Ω |
| Solid-state devices: | • IC...4, FET...4, Transistors...35, Diodes...13 |
| Power supply: | • AC 120V 60 Hz only |
| Power consumption: | • 22 watts |
| Dimensions (W x H x D): | • 18 1/16" x 8 9/16" x 13 1/16" |
| Weight: | • 22 lb. |

ACCESSORIES

- Discrete 4-channel Test disc1
- Connection Cords2
(PIN-PIN type)
- Stylus cleaner.....1

NEW JERSEY TECH. ASSISTANCE 3/21/90

201-348-9090

MATSUSHITA ELECTRIC CORP. OF AMERICA

Pan-Am Bldg., 200 Park Ave. New York, N.Y. 10017

MATSUSHITA ELECTRIC OF HAWAII, INC.

320 Waiakamilo Road, Honolulu, Hawaii 96817

MATSUSHITA ELECTRIC OF CANADA LTD.

40 Ronson Drive, Rexdale, Ont.

NORTH COUNTY STARS
753-3546

Bill
mm

CARTRIDGE 4 CHANNEL # 4510
EPC-451C

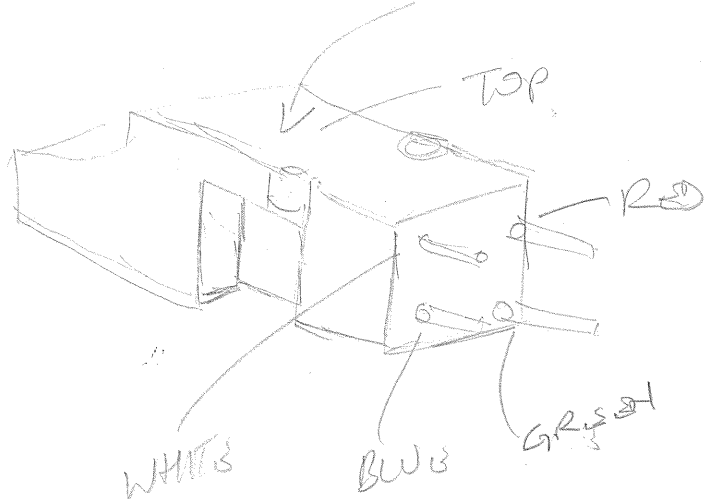

MATSUSHITA ELECTRIC
INDUSTRIAL CO LTD

ON R SIDE A

" L " 4312